

Process industry bimetal thermometer

Model : T120

Spec. sheet no. TD01-05

Service intended

Bimetal thermometer is used for measuring temperature of gas or fluid. It is suitable for measurement, regulation, and direct monitoring for the fluid. It meets the most stringent criteria on resistance to a corrosive atmosphere and exceptional climatic circumstances.



Nominal diameter

75 and 100 mm

Accuracy

±2.0 % of full scale

Temperature element

Coiled bimetal

Working range

Maximum scale value

Degree of protection

EN60529/IEC529/IP65 (100 mm)



Standard features

Location of stem

Bottom connection, direct

Pointer

Black painted aluminium alloy

Case

304SS

Stem

6.0, 6.4, 8.0 and 10.0 mm diameter
304SS, 316SS and 316L SS
Max. Insertion length : 2,000 mm

Cover

304SS

Zero adjustment

Internal

Window

Glass

Stem, process connection

¼", ⅜", ½", ¾" PT, NPT and PF

Dial

White aluminium with black graduations

Option

±1.0 % of full scale

Main order

Ordering information

1. Base model

T120 Process industry bimetal thermometer

2. Nominal diameter (mm)

- 3 75
- 4 100

3. Type of mounting

W Bottom connection, direct

4. Stem material

- 0 304SS
- 1 316SS
- 2 316L SS

5. Stem, process connection

- A None
- C ¼"
- D ⅜"
- E ½"
- F ¾"
- G 1½S (Only available with sanitary)
- H 2S (Only available with sanitary)
- I 2½S (Only available with sanitary)

6. Stem connection type (CF: Compression fitting)

- A None
- B PF
- C PT
- D NPT
- E CF + PT
- F CF + NPT
- G CF + PF
- H MT + PT (Movable thread)
- I MT + NPT (Movable thread)
- J MT + PF (Movable thread)
- S Clamp (Sanitary type flange)

7. Stem outer diameter (mm)

- 0 6.0
- 1 6.4
- 2 8.0
- 3 10.0 (Not available process connection, ¼")

8. Range

XXX Refer to scale range table

9. Insertion length

X Refer to insertion length table

10. Accessories

- 0 None
- 1 Thermowell
- 2 Special accuracy (±1.0 % of full scale)
- 3 Thermowell and special accuracy

1	2	3	4	5	6	7	8	9	10
T120	4	W	0	E	C	1	XXX	X	1

Sample
ordering code



© WISE Control Inc. All rights reserved. ALL PRODUCT, PRODUCT SPECIFICATIONS AND DATA ARE SUBJECT TO CHANGE WITHOUT NOTICE TO IMPROVE RELIABILITY, FUNCTION OR DESIGN OR OTHERWISE.

T120 : Type of mounting

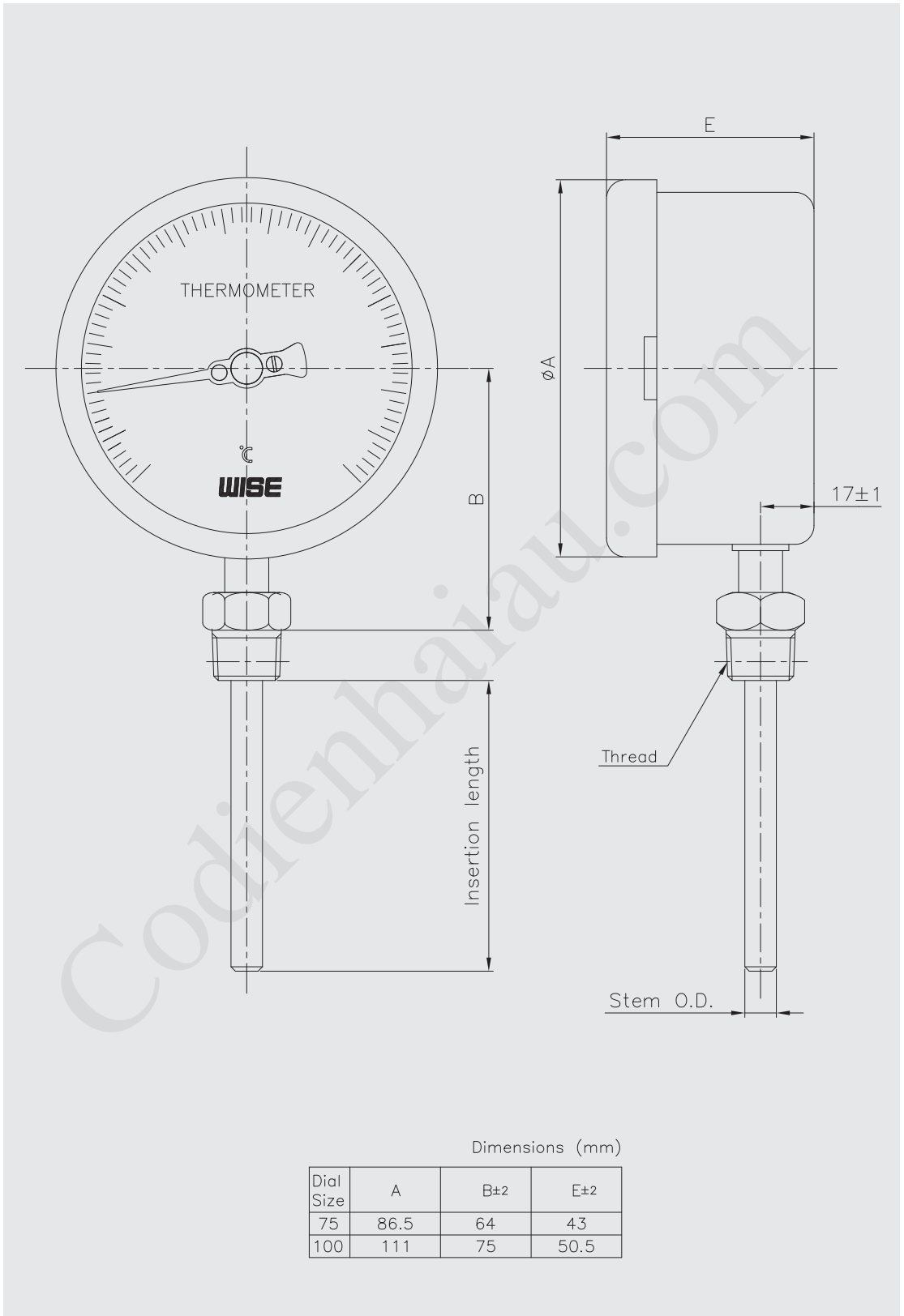

Scale ranges

Code	Scale range (°C)	Scale spacing (°C)	Minimum stem length (mm)	
			6.0 and 6.4	8.0 and 10.0
032	-50 ~ 50	2	55	50
037	-50 ~ 100	2	45	35
054	-30 ~ 50	2	70	60
059	-30 ~ 100	2	50	45
061	-30 ~ 120	2	45	35
069	-20 ~ 50	2	80	70
074	-20 ~ 100	2	45	45
079	-20 ~ 150	5	40	35
084	-10 ~ 50	1	95	80
099	0 ~ 50	1	110	70
100	0 ~ 60	1	95	80
101	0 ~ 70	2	80	60
102	0 ~ 80	2	70	55
104	0 ~ 100	2	55	50
106	0 ~ 120	2	50	45
109	0 ~ 150	2	45	35
114	0 ~ 200	5	35	35
119	0 ~ 250	5	35	30
124	0 ~ 300	5	35	25
129	0 ~ 350	5	30	25
134	0 ~ 400	5	80	65
144	0 ~ 500	10	70	60
154	0 ~ 600	10	70	60

Insertion length

Code	1	2	3	4	5	6	7	8	9	A	B	C
Length (mm)	50	60	70	80	100	120	130	150	175	200	225	250

Code	D	E	F	G	H	J	K	L	M	N	P
Length (mm)	275	300	350	375	400	450	500	550	1,000	1,500	2,000