

2.1 Product Overview

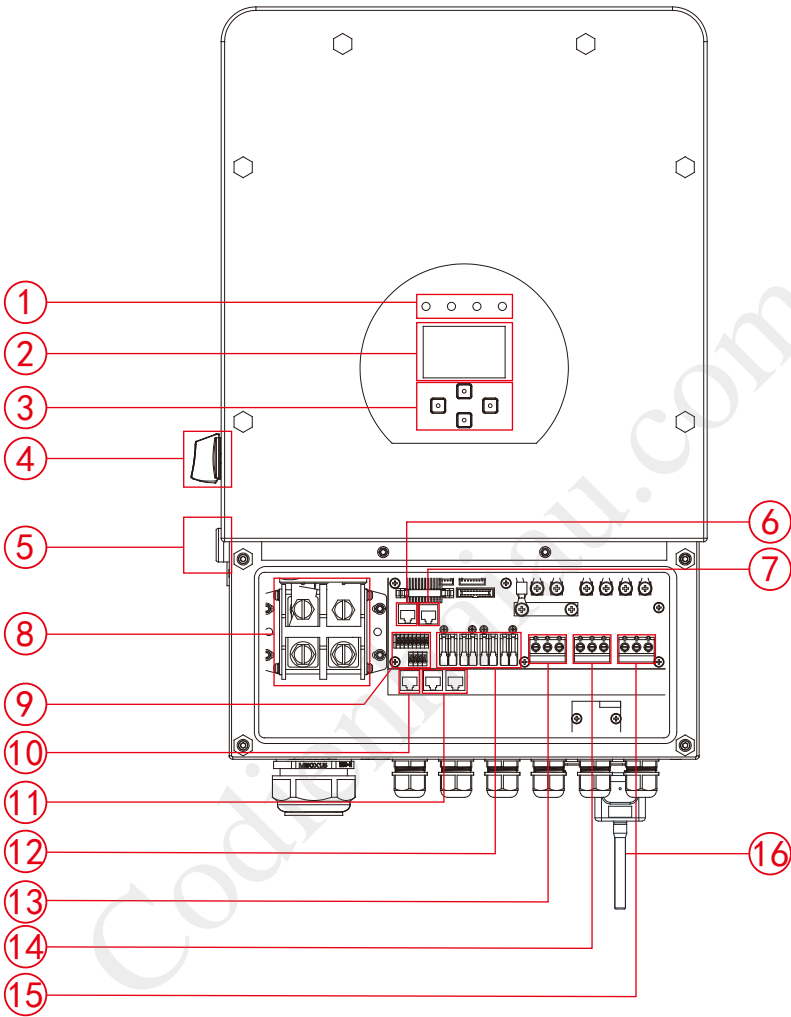

1: Inverter Indicators

2: LCD display

3: Function Buttons

4: DC Switch

5: Power on/off button

6: RS 485 Port

7: CAN Port

8: Battery input connectors

9: Function Port

10: Parallel Box(master)

11: Parallel port

12: PV input with two MPPT

13: Grid

14: Generator input

15: Load

16: WiFi Interface

2.2 Product Features

- Supports Split phase 120/240Vac, Three-phase 120/208Vac system.
- Self-consumption and feed-in to the grid.
- Auto restart while AC is recovering.
- Programmable supply priority for battery or grid.
- Programmable multiple operation modes: On grid, off grid and UPS.
- Configurable battery charging current/voltage based on applications by LCD setting.
- Configurable AC/Solar/Generator Charger priority by LCD setting.
- Compatible with mains voltage or generator power.
- Overload/over temperature/short circuit protection.
- Smart battery charger design for optimized battery performance
- With limit function, prevent excess power overflow to the grid.
- Supporting WIFI monitoring and build-in 2 strings of MPP trackers
- Smart settable three stages MPPT charging for optimized battery performance.
- Time of use function.
- Smart Load Function.

2.3 Basic System Architecture

The following illustration shows basic application of this inverter.

It also includes following devices to have a Complete running system.

- Generator or Utility
- PV modules

Consult with your system integrator for other possible system architectures depending on your requirements.

This inverter can power all kinds of appliances in home or office environment, including motor type appliances such as refrigerator and air conditioner.

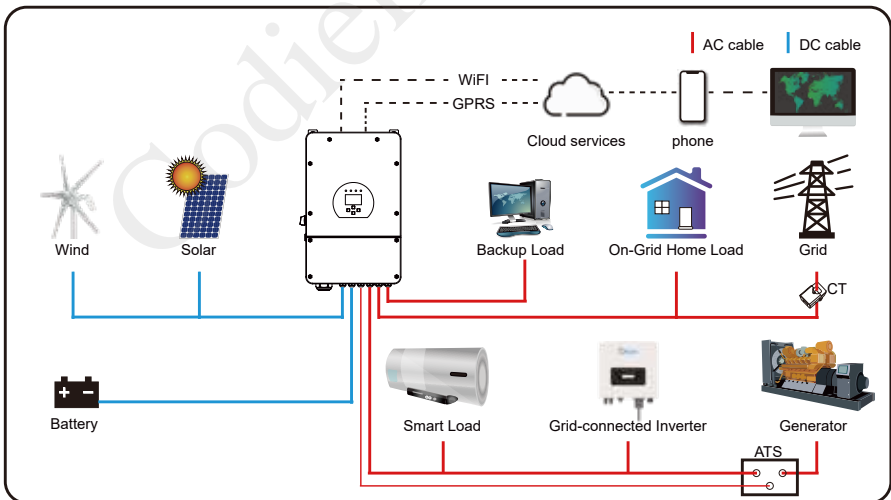

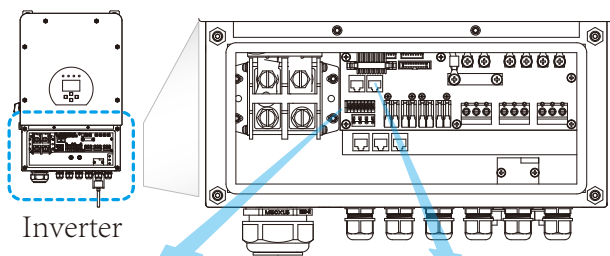

Inverter

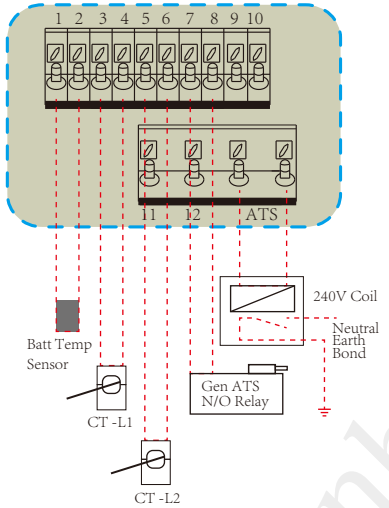

TEMP (1,2): battery temperature sensor for lead acid battery.

CT-L1 (3,4): current transformer (CT1) for "zero export to CT" mode clamps on L1 when in split phase system.

CT-L2 (5,6): current transformer (CT2) for "zero export to CT" mode clamps on L2 when in split phase system.

G-start (7,8): dry contact signal for startup the diesel generator.

When the "GEN signal" is active, the open contact (GS) will switch on (no voltage output).

G-valve (9,10): reserved.

RSD (11,12): provide 12Vdc output when inverter is on.

ATS: 230V output port when inverter is on

Note: For - EU model (7.6/8kW,230V@50Hz), 1pcs CT is needed only, and the secondary side of the CT should be connected to 5&6 port (CT-L2).

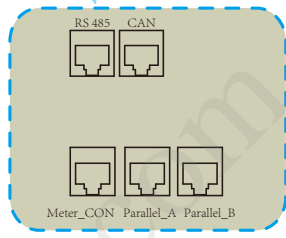

RS 485: RS 485 port for battery communication.

CAN: CAN port for battery communication.

Parallel A: Parallel communication port 1 (CAN interface).

Parallel B: Parallel communication port 2 (CAN interface).

Meter_CON: for energy meter communication.

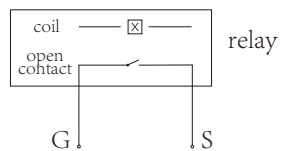

GS (diesel generator startup signal)

3.3.2 Battery temperature connection

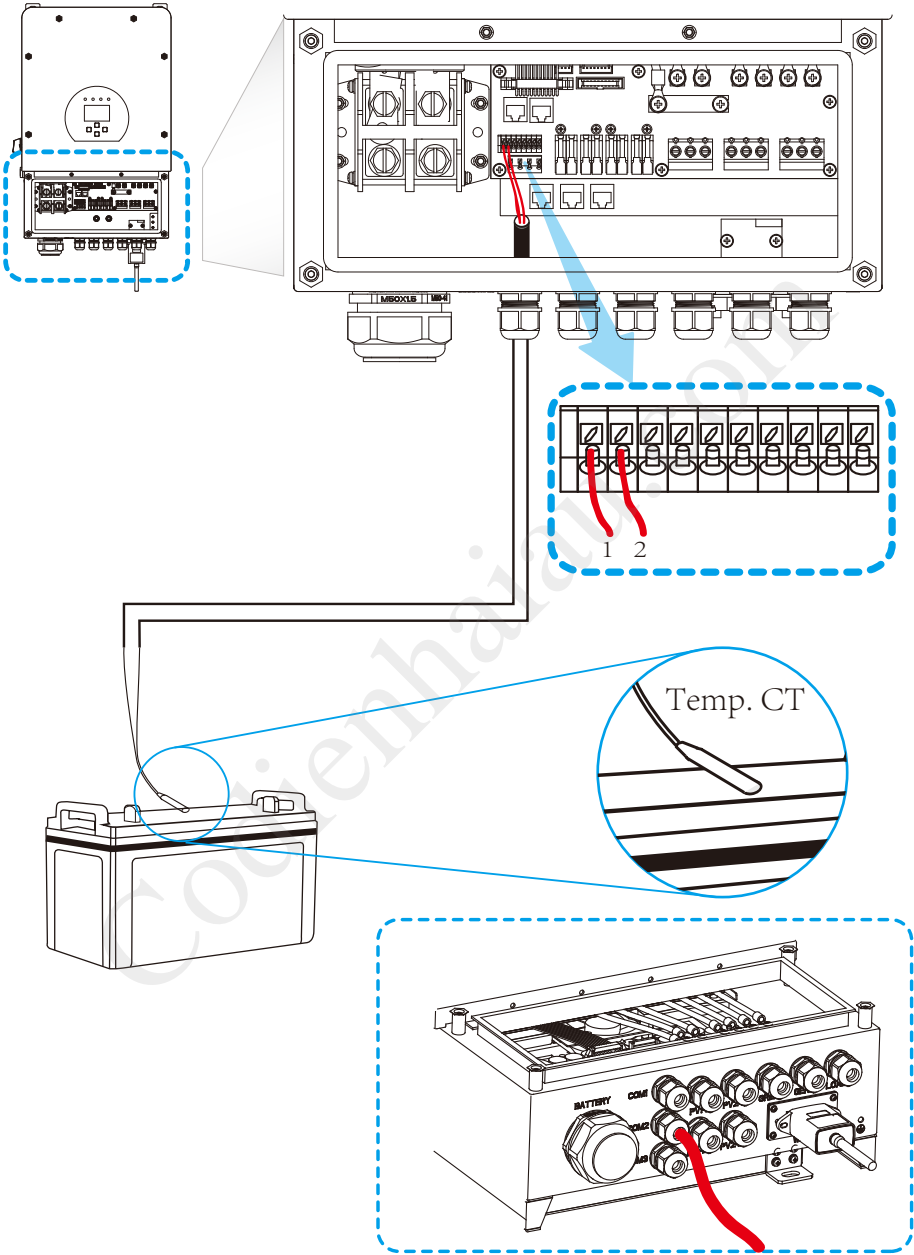

3.9 Wiring System for Inverter

(Region:EU)

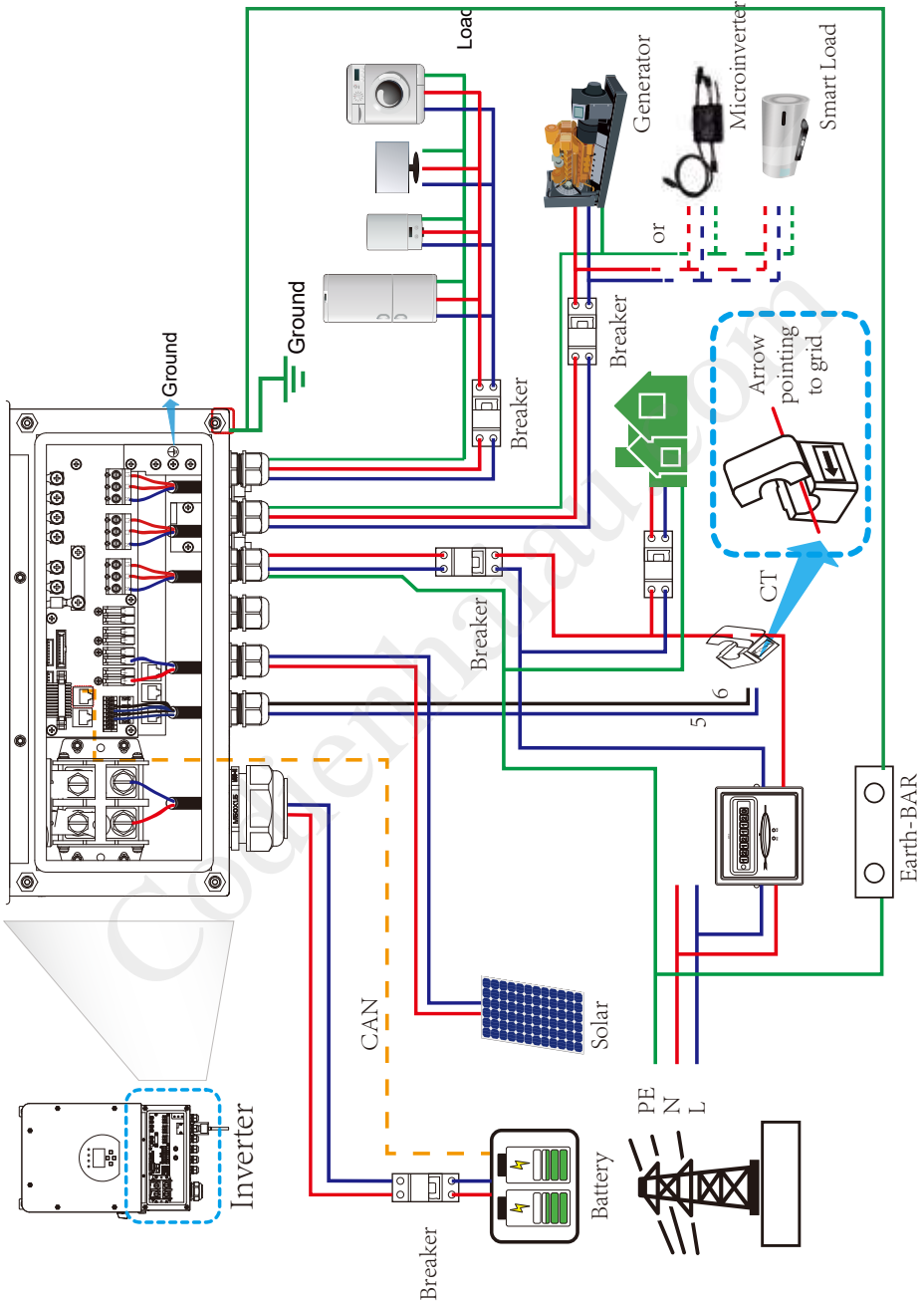

3.10 Single phase parallel connection diagram

(Region:EU)

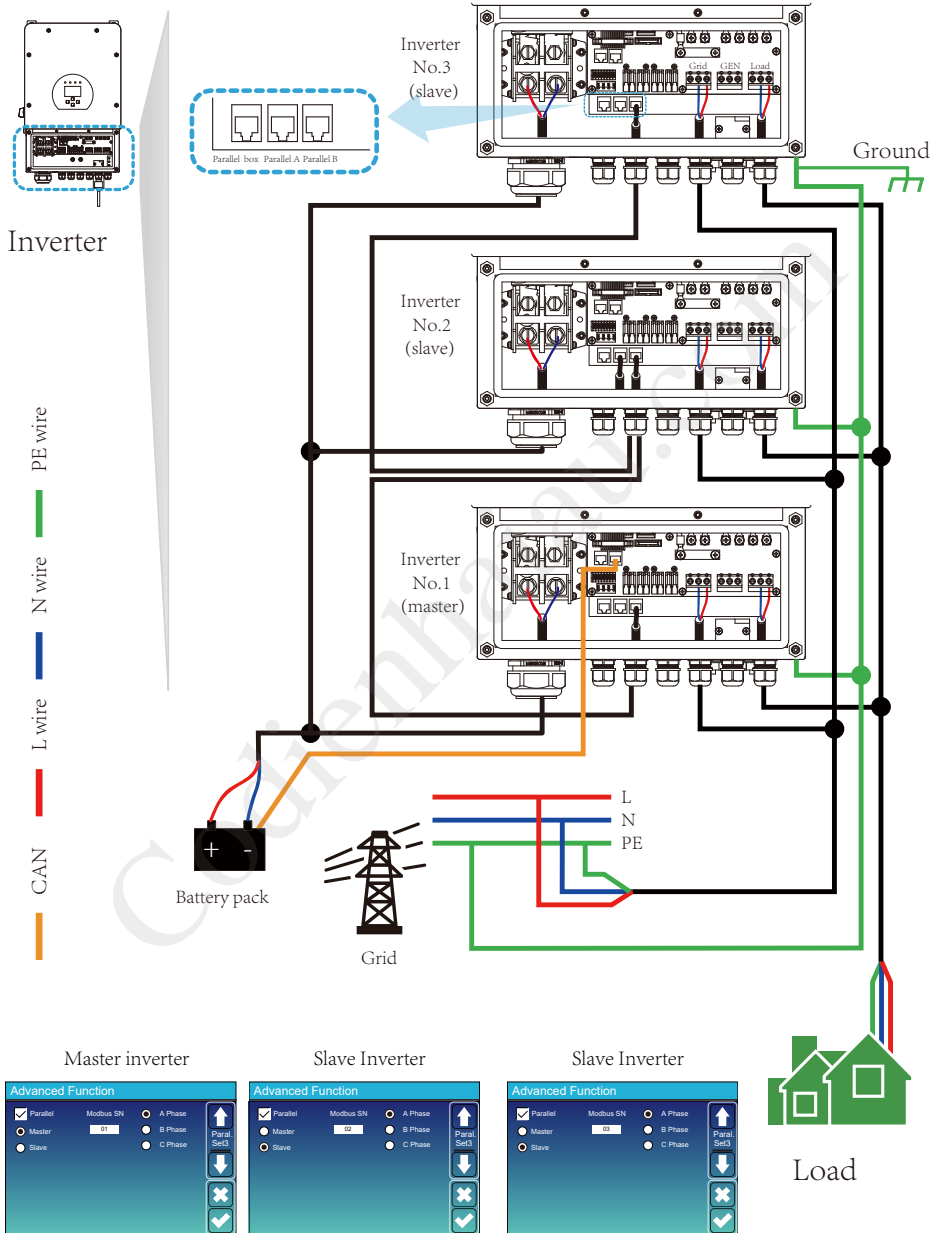

3.12 Three phase Parallel Inverter

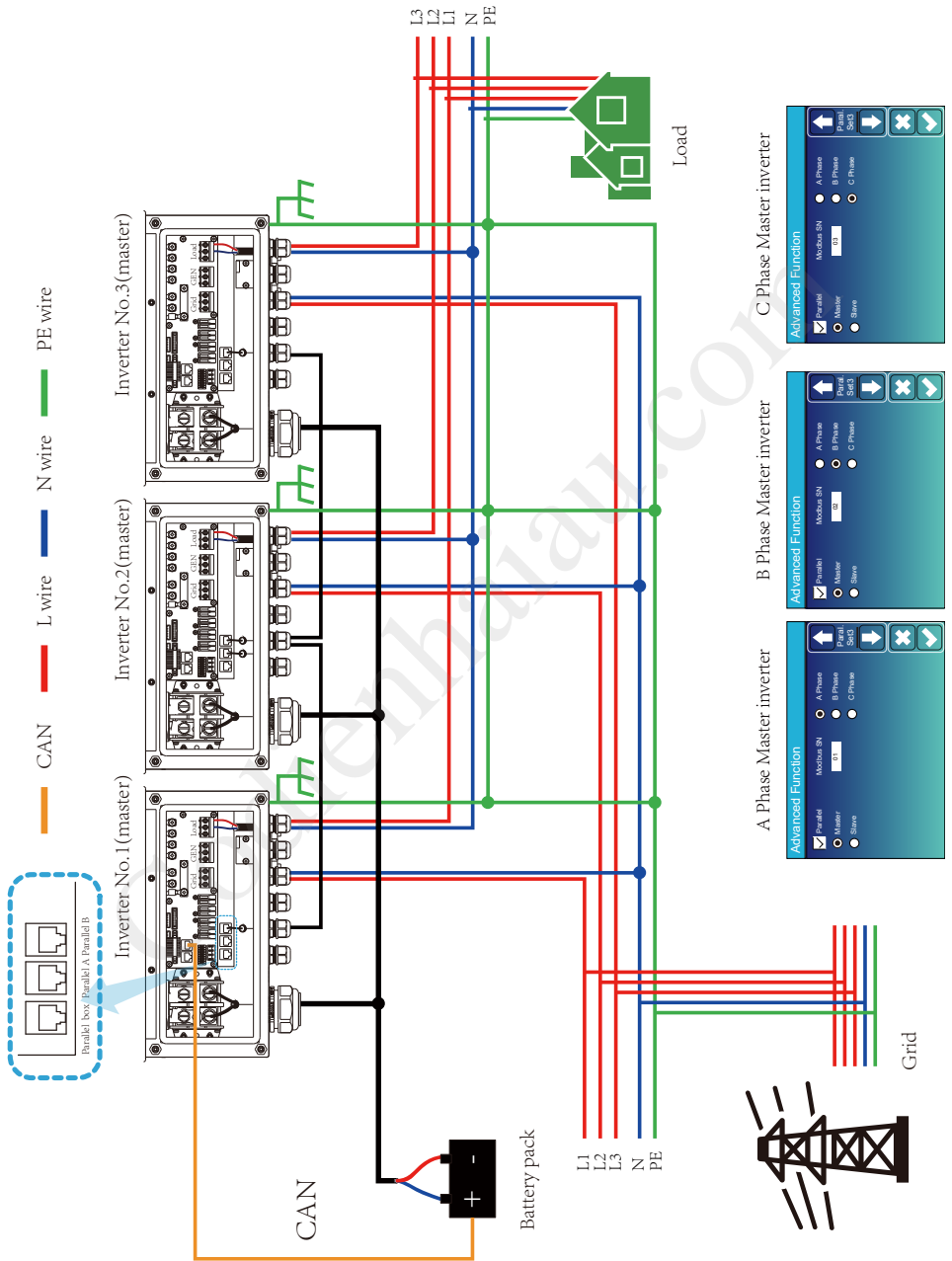

3.13 Parallel connection for 120/208 three phase

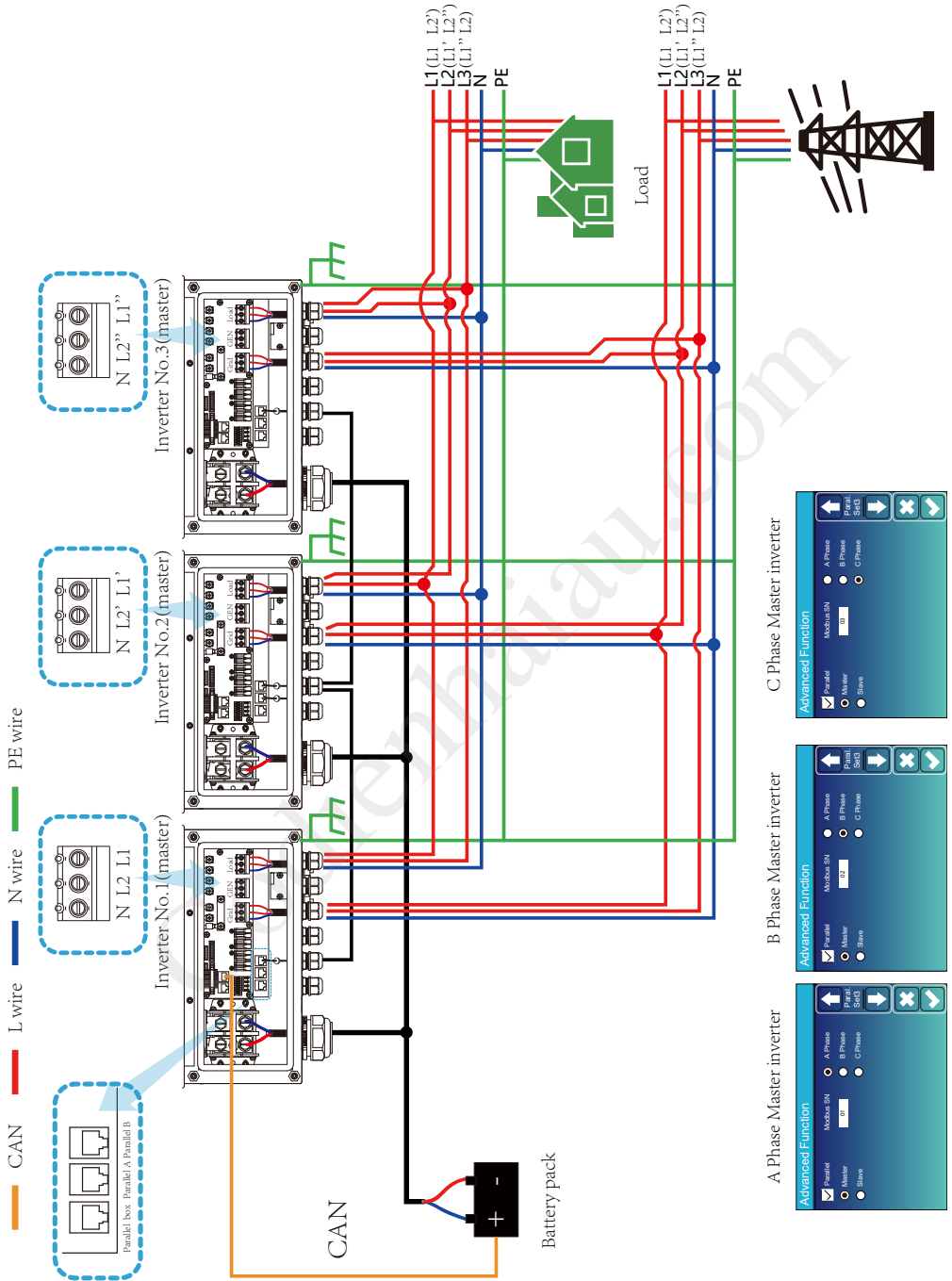

5.1.1 LCD operation flow chart

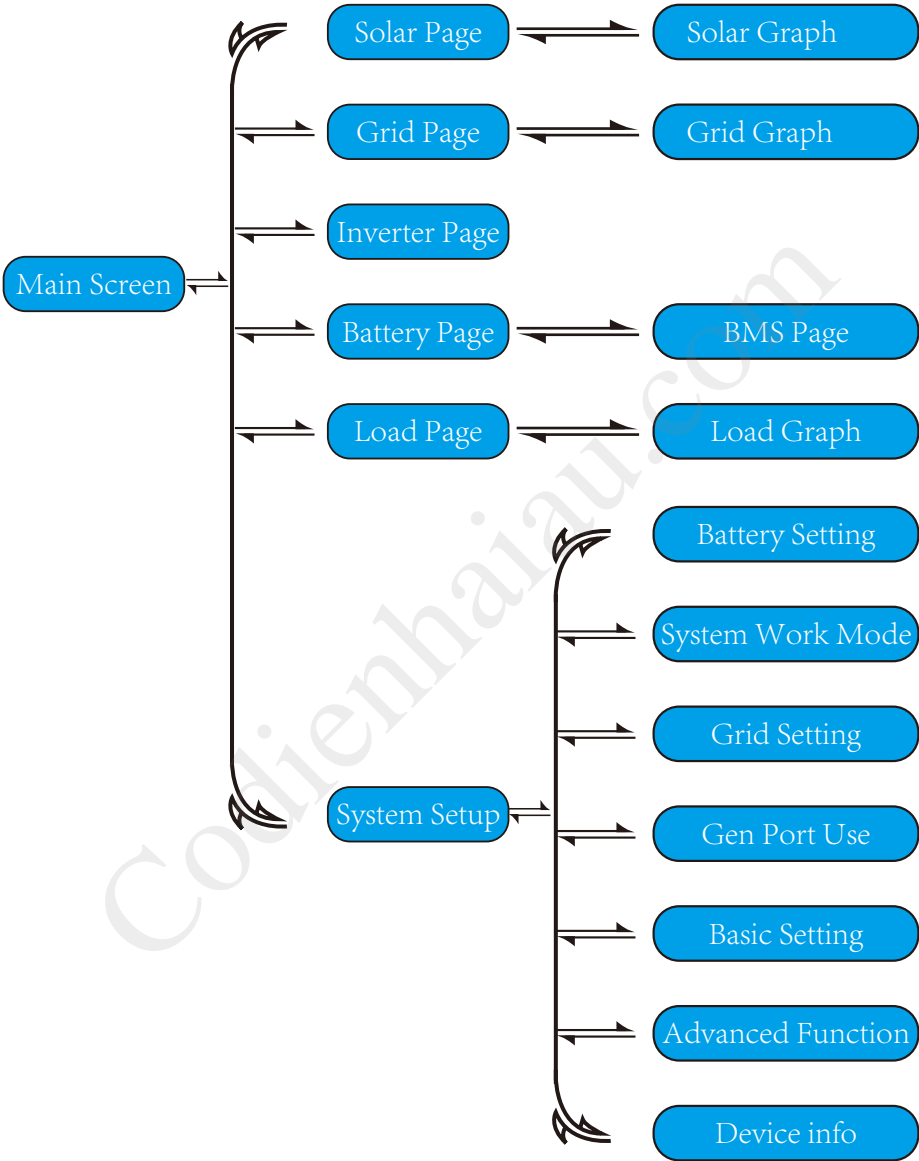

5.2 Solar Power Curve

Solar

Power: 1560W ①

PV1-V: 286V PV2-V: 45V ②

PV1-I: 5.5A PV2-I: 0.0A

P1: 1559W P2: 1W

Today=8.0 KWH ③

Total =12.00 KWH

Energy

This is Solar Panel detail page.

- ① Solar Panel Generation.
- ② Voltage, Current, Power for each MPPT.
- ③ Solar Panel energy for Day and Total.

Press the “Energy “button will enter into the power curve page.

Inverter

Power: 44W ①

L1: 240V ②

I1:0.6A

DC-T:52.6C ③

AC-T:41.0C

Energy

This is Inverter detail page.

- ① Inverter Generation.
- ② Voltage, Current, Power for each Phase.
- ③ *DC-T: mean DC-DC temperature,
AC-T: mean Heat-sink temperature.
*Note: this part info is not available for some LCD FW.

Load

Power: 0W ①

L: 0V ②

Today=0.0 KWH ③

Total =0.40 KWH

Energy

This is Back-up Load detail page.

- ① Back-up Power.
- ② Voltage, Power for each Phase.
- ③ Back-up consumption for Day and Total.

Press the “Energy “ button will enter into the power curve page.

Grid

Stand-by ①

Power: 0W

0.0Hz

L1: 0V L2: 0V ②

CT1: 0W CT2: 0W

LD1: 0W LD2: 0W

BUY ③

Today=2.2KWH

Total =11.60 KWH

SELL

Today=0.0KWH

Total =8.60 KWH

Energy

This is Grid detail page.

- ① Status, Power, Frequency.
- ② L1&L2: Voltage for each Phase
CT1&CT2: External Current Sensor Power
LD1&LD2: Internal Current Sensor Power.
- ③ BUY: Energy from Grid to Inverter,
SELL: Energy from Inverter to Load.

Press the “Energy “ button will enter into the power curve page.

5.4 System Setup Menu

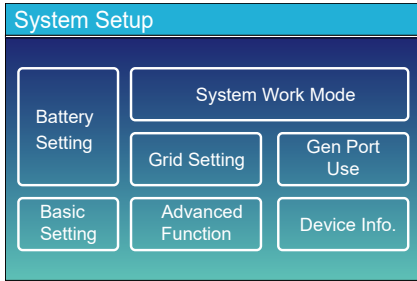

This is System Setup page.

5.5 Basic Setup Menu

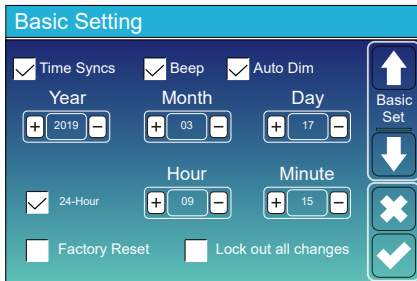

Factory Reset: Reset all parameters of the inverter.
Lock out all changes: Enable this menu for setting parameters that require locking and cannot be set up. Before performing a successful factory reset and locking the systems, to keep all changes you need to type in a password to enable the setting. The password for factory settings is 9999 and for lock out is 7777.

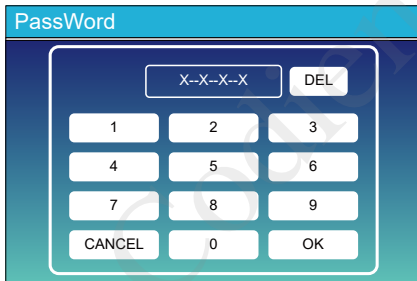

Factory Reset PassWork: 9999

Lock out all changes PassWork: 7777

5.6 Battery Setup Menu

Battery Setting

Batt Mode

Lithium Batt Capacity 400Ah

Use Batt V Max A Charge 40A

Use Batt % Max A Discharge 40A

No Batt Activate Battery

Batt Mode

Battery capacity: it tells Deye hybrid inverter to know your battery bank size.

Use Batt V: Use Battery Voltage for all the settings (V).

Use Batt %: Use Battery SOC for all the settings (%).

Max. A charge/discharge: Max battery charge/discharge current(0-115A for 5KW model, 0-90A for 3.6KW model). For AGM and Flooded, we recommend Ah battery size x 20%= Charge/Discharge amps.

. For Lithium, we recommend Ah battery size x 50% = Charge/Discharge amps.

. For Gel, follow manufacturer' s instructions.

No Batt: tick this item if no battery is connected to the system.

Active battery: This feature will help recover a battery that is over discharged by slowly charging from the solar array or grid.

Battery Setting

Start 30% 30%

A 40A 40A

Gen Charge Grid Charge

Gen Signal Grid Signal

Gen Max Run Time 0.0 hours

Gen Down Time 0.5 hours

Batt Set2

This is Battery Setup page. ① ③

Start =30%: Percent S.O.C at 30% system will AutoStart a connected generator to charge the battery bank.

A = 40A: Charge rate of 40A from the attached generator in Amps.

Gen Charge: uses the gen input of the system to charge battery bank from an attached generator.

Gen Signal: Normally open relay that closes when the Gen Start signal state is active.

Gen Max Run Time: It indicates the longest time Generator can run in one day, when time is up, the Generator will be turned off. 24H means that it does not shut down all the time.

Gen Down Time: It indicates the delay time of the Generator to shut down after it has reached the running time.

This is Grid Charge, you need select. ②

Start =30%: No use, Just for customization.

A = 40A: It indicates the Current that the Grid charges the Battery.

Grid Charge: It indicates that the grid charges the battery.

Grid Signal: Disable.

Battery Setting

Lithium Mode 00

Shutdown 10%

Low Batt 20%

Restart 40%

Batt Set3

Lithium Mode: This is BMS protocol.Please reference the document(Approved Battery).

Shutdown 10%: It indicates the inverter will shutdown if the SOC below this value.

Low Batt 20%: It indicates the inverter will alarm if the SOC below this value.

Restart 40%: Battery voltage at 40% AC output will resume.

Battery Setting

Float V ①	53.6V	Shutdown ③	20%	↑ Batt Set3 ↓ ✕ ✓
Absorption V	57.6V	Low Batt	35%	
Equalization V	57.6V	Restart	50%	
Equalization Days	30 days	TEMPCO(mV/C/Cell)	② -5	
Equalization Hours	3.0 hours	Batt Resistance	25mOhms	

There are 3 stages of charging the Battery . **①**

This is for professional installers, you can keep it if you do not know. **②**

Shutdown 20%: The inverter will shutdown if the SOC below this value.

Low Batt 35%: The inverter will alarm if the SOC below this value. **③**

Restart 50%: Battery SOC at 50% AC output will resume.

Recommended battery settings

Battery Type	Absorption Stage	Float Stage	Torque value (every 30 days 3hr)
AGM (or PCC)	14.2v (57.6v)	13.4v (53.6v)	14.2v(57.6v)
Gel	14.1v (56.4v)	13.5v (54.0v)	
Wet	14.7v (59.0v)	13.7v (55.0v)	14.7v(59.0v)
Lithium	Follow its BMS voltage parameters		

5.7 System Work Mode Setup Menu

System Work Mode

Selling First 8000 Max Solar Power

Zero Export To Load Solar Sell

Zero Export To CT Solar Sell

Max Sell Power 8000 Zero-export Power 20

Energy pattern BattFirst LoadFirst

Grid Peak Shaving 8000 Power

↑
Work Mode1

↓

✕

✓

Work Mode

Selling First: This Mode allows hybrid inverter to sell back any excess power produced by the solar panels to the grid. If time of use is active, the battery energy also can be sold into grid.

The PV energy will be used to power the load and charge the battery and then excess energy will flow to grid.

Power source priority for the load is as follows:

1. Solar Panels.
2. Grid.
3. Batteries (until programmable % discharge is reached).

Zero Export To Load: Hybrid inverter will only provide power to the backup load connected. The hybrid inverter will neither provide power to the home load nor sell power to grid. The built-in CT will detect power flowing back to the grid and will reduce the power of the inverter only to supply the local load and charge the battery.

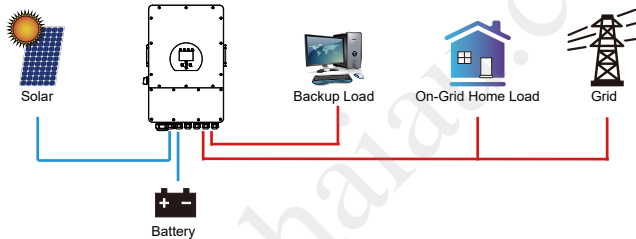

Zero Export To CT: Hybrid inverter will not only provide power to the backup load connected but also give power to the home load connected. If PV power and battery power is insufficient, it will take grid energy as supplement. The hybrid inverter will not sell power to grid. In this mode, a CT is needed. The installation method of the CT please refer to chapter 3.6 CT Connection. The external CT will detect power flowing back to the grid and will reduce the power of the inverter only to supply the local load, charge battery and home load.

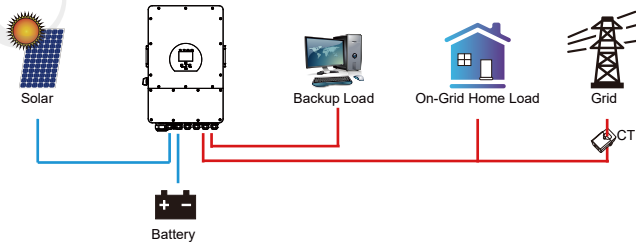

Solar Sell: "Solar sell" is for Zero export to load or Zero export to CT: when this item is active, the surplus energy can be sold back to grid. When it is active, PV Power source priority usage is as follows: load consumption and charge battery and feed into grid.

Max. sell power: Allowed the maximum output power to flow to grid.

Zero-export Power: for zero-export mode, it tells the grid output power. Recommend to set it as 20-100W to ensure the hybrid inverter won't feed power to grid.

Energy Pattern: PV Power source priority.

Batt First: PV power is firstly used to charge the battery and then used to power the load. If PV power is insufficient, grid will make supplement for battery and load simultaneously.

Load First: PV power is firstly used to power the load and then used to charge the battery. If PV power is insufficient, grid will make supplement for battery and load simultaneously.

Max Solar Power: allowed the maximum DC input power.

Grid Peak-shaving: when it is active, grid output power will be limited within the set value. If the load power exceeds the allowed value, it will take PV energy and battery as supplement. If still can't meet the load requirement, grid power will increase to meet the load needs.

System Work Mode						
Grid Charge	Gen	Time Of Use		Power	Batt	Work Mode2
		Time	Power			
<input type="checkbox"/>	<input type="checkbox"/>	01:00	5:00	8000	49.0V	↑
<input type="checkbox"/>	<input type="checkbox"/>	05:00	9:00	8000	50.2V	↓
<input checked="" type="checkbox"/>	<input type="checkbox"/>	09:00	13:00	8000	50.9V	✕
<input checked="" type="checkbox"/>	<input type="checkbox"/>	13:00	17:00	8000	51.4V	✕
<input checked="" type="checkbox"/>	<input type="checkbox"/>	17:00	21:00	8000	47.1V	✕
<input checked="" type="checkbox"/>	<input type="checkbox"/>	21:00	01:00	8000	49.0V	✓

Time of use: it is used to program when to use grid or generator to charge the battery, and when to discharge the battery to power the load. Only tick "Time Of Use" then the follow items (Grid, charge, time, power etc.) will take effect.

Note: when in selling first mode and click time of use, the battery power can be sold into grid.

Grid charge: utilize grid to charge the battery in a time period.

Gen charge: utilize diesel generator to charge the battery in a time period.

Time: real time, range of 01:00-24:00.

Power: Max. discharge power of battery allowed.

Batt(V or SOC %): battery SOC % or voltage at when the action is to happen.

System Work Mode						
Grid Charge	Gen	Time Of Use		Power	Batt	Work Mode2
		Time	Power			
<input checked="" type="checkbox"/>	<input type="checkbox"/>	01:00	5:00	8000	80%	↑
<input type="checkbox"/>	<input type="checkbox"/>	05:00	8:00	8000	40%	↓
<input type="checkbox"/>	<input type="checkbox"/>	08:00	10:00	8000	40%	↓
<input type="checkbox"/>	<input type="checkbox"/>	10:00	15:00	8000	80%	↓
<input type="checkbox"/>	<input type="checkbox"/>	15:00	18:00	8000	40%	↓
<input type="checkbox"/>	<input type="checkbox"/>	18:00	01:00	8000	35%	✓

For example:

During 01:00-05:00, when battery SOC is lower than 80%, it will use grid to charge the battery until battery SOC reaches 80%.

During 05:00-08:00 and 08:00-10:00, when battery SOC is higher than 40%, hybrid inverter will discharge the battery until the SOC reaches 40%.

During 10:00-15:00, when battery SOC is higher than 80%, hybrid inverter will discharge the battery until the SOC reaches 80%.

During 15:00-18:00, when battery SOC is higher than 40%, hybrid inverter will discharge the battery until the SOC reaches 40%.

During 18:00-01:00, when battery SOC is higher than 35%, hybrid inverter will discharge the battery until the SOC reaches 35%.

5.8 Grid Setup Menu

Grid Setting

Grid Mode

- General Standard
- UL1741 & IEEE1547
- CPUC RULE21
- SRD-UL-1741

Grid Type

- 220V Single Phase
- 120/240V Split Phase
- 120/208V 3 Phase
- 120V Single Phase

Grid Set1

Please select the correct Grid Mode in your local area. If you are not sure, please choose General Standard.

Please select the correct Grid Type in your local area, otherwise the machine will not work or be damaged.

Grid Setting

Grid Frequency

- 50HZ
- 60HZ

Reconnection Time PF

Grid HZ High Grid Vol High

Grid HZ Low Grid Vol Low

Grid Set2

UL1741&IEEE1547, CPUC RULE21, SRD-UL-1741

No need to set the function of this interface.

General Standard

Please select the correct Grid Frequency in your local area.

You can hold this in default value.

Grid Setting

Q(V) FW VW

V1:0.0V Q1:0.00 Fstart:0.00Hz Vstart:0.0V

V2:0.0V Q2:0.00 Fstop:0.00Hz Vstop:0.0V

V3:0.0V Q3:0.00 Normal Ramp rate

V4:0.0V Q4:0.00 Soft Start Ramp rate

Grid Set3

For California only.

Grid Setting

L/HVRT L/HFRT

HV2:0.0V

HV1:0.0V HF2:0.00HZ

LV1:0.0V HF1:0.00HZ

LV2:0.0V LF1:0.00HZ

LV3:0.0V LF2:0.00HZ

Grid Set4

For California only.

5.9 Generator Port Use Setup Menu

GEN PORT USE

Mode

Generator Input GEN connect to Grid Input
Rated Power: 8000W

SmartLoad Output On Grid always on
Power: 500W AC Couple Fre High: 52.00Hz OFF: 95%

Micro Inv Input ON: 100%
 MI export to Grid cutoff

PORT Set1

↑

↓

✕

✓

Generator input rated power: allowed Max. power from diesel generator.

GEN connect to grid input: connect the diesel generator to the grid input port.

Smart Load Output: This mode utilizes the Gen input connection as an output which only receives power when the battery SOC and PV power is above a user programmable threshold.

e.g. Power=500W, ON: 100%, OFF=95%: When the PV power exceeds 500W, and battery bank SOC reaches 100%, Smart Load Port will switch on automatically and power the load connected. When the battery bank SOC < 95% or PV power < 500w, the Smart Load Port will switch off automatically.

Smart Load OFF Batt

- Battery SOC at which the Smart load will switch off. Smart Load ON Batt.
- Battery SOC at which the Smart load will switch on. And at the same time, the PV input power should exceed the setting value (Power) simultaneously and then the Smart load will switch on.

On Grid always on: When click "on Grid always on" the smart load will switch on when the grid is present.

Micro Inv Input: To use the Generator input port as a micro-inverter on grid inverter input (AC coupled), this feature will also work with "Grid-Tied" inverters.

* Micro Inv Input OFF: When battery SOC exceeds setting value, Microinverter or grid-tied inverter will shut down.

* Micro Inv Input ON: When battery SOC is lower than setting value, microinverter or grid-tied inverter will shut down.

AC Couple Fre High: If choosing "Micro Inv input", as the battery SOC reaches gradually setting value (OFF), During the process, the microinverter output power will decrease linear. When the battery SOC equals to the setting value (OFF), the system frequency will become the setting value (AC couple Fre high) and the Microinverter will stop working.

MI export to grid cutoff: Stop exporting power produced by the microinverter to the grid.

* Note: Micro Inv Input OFF and On is valid for some certain FW version only.

5.10 Advanced Function Setup Menu

Advanced Function

Solar Arc Fault ON Backup Delay: 0S

Clear Arc_Fault

System selfcheck Gen peak-shaving

DRM CT Ratio: 2000: 1

Signal ISLAND MODE

BMS_Err_Stop

Func Set1

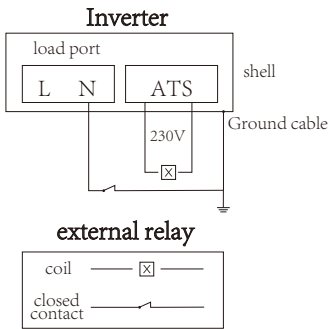

Solar Arc Fault ON: This is only for US.

System selfcheck: Disable. this is only for factory.

Gen Peak-shaving: Enable When the power of the generator exceeds the rated value of it, the inverter will provide the redundant part to ensure that the generator will not overload.

DRM: For AS4777 standard

Backup Delay: Reserved

BMS_Err_Stop: When it is active, if the battery BMS failed to communicate with inverter, the inverter will stop working and report fault.

Signal island mode: when the inverter connects grid, the ATS port will output 230Vac and it is used to cuts off Earth-Neutral(load port N line) bond via connect external relay. When the inverter disconnects from the grid, ATS port voltage will be 0 and the Earth-Neutral bond keeps on. More details, please refer to left picture.

Advanced Function

Parallel Modbus SN: 00 A Phase

Master B Phase

Slave C Phase

Ex_Meter For CT

A Phase

B Phase

C Phase

Paral. Set3

Ex_Meter For CT: when in Three phase system with CHNT Three phase energy meter (DTSU666), click corresponding phase where hybrid inverter is connected. e.g. when the hybrid inverter output connects to A phase, please click A Phase.

Advanced Function

DC1 for WindTurbine DC2 for WindTurbine

V1	0V	0.0A	V7	0V	0.0A
V2	0V	0.0A	V8	0V	0.0A
V3	0V	0.0A	V9	0V	0.0A
V4	0V	0.0A	V10	0V	0.0A
V5	0V	0.0A	V11	0V	0.0A
V6	0V	0.0A	V12	0V	0.0A

Wind Set2

This is for Wind Turbine

Note: This interface is not available for some firmware version

5.11 Device Info Setup Menu

Device Info.		
Inverter ID: 1601012001	Flash	Device Info
HMI: Ver0302	MAIN: Ver2138	
Alarms Code	Occurred	
F64 Heatsink_HighTemp_Fault	2019-03-11 15:56	
F64 Heatsink_HighTemp_Fault	2019-03-08 10:46	
F64 Heatsink_HighTemp_Fault	2019-03-08 10:45	

This page show Inverter ID, Inverter version and alarm codes.

HMI: LCD version

MAIN: Control board FW version

6. Mode

Mode I: Basic

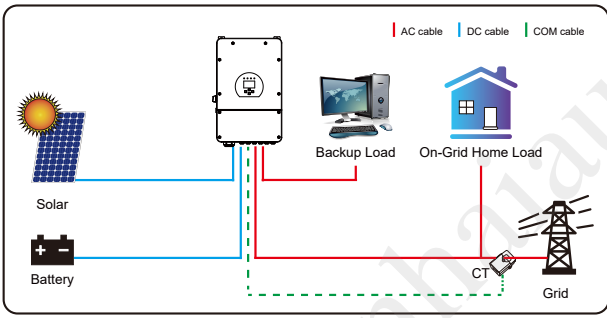

Mode II: With Wind Turbine

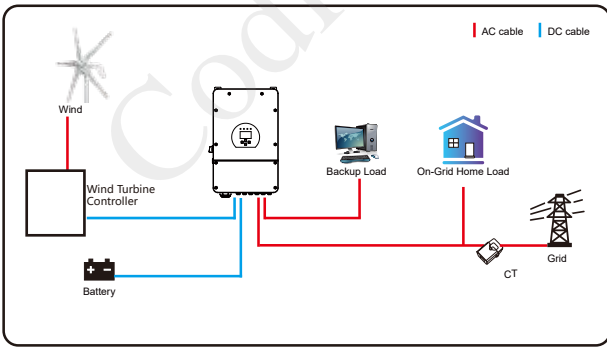

Mode III: With Generator

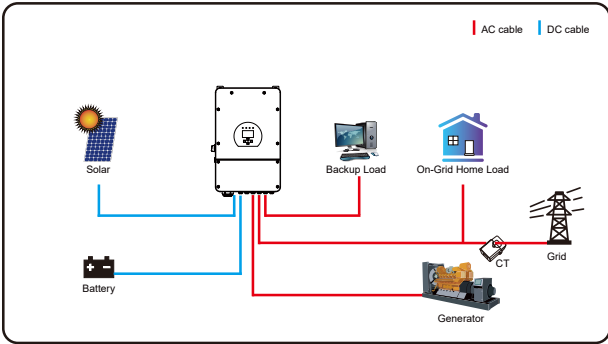

Mode IV: With Smart-Load

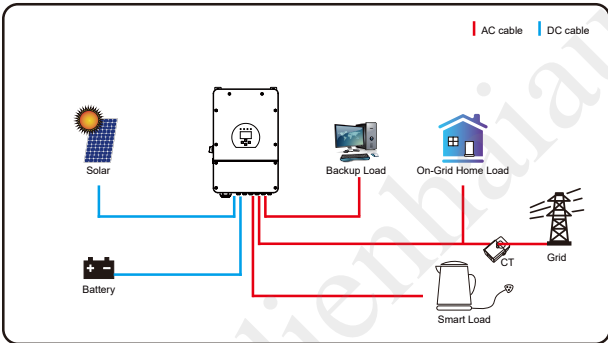

Mode V: AC Couple

